

# Tower Crane NC-B 9-62

NC-B 6-62  
NC-B 9-62

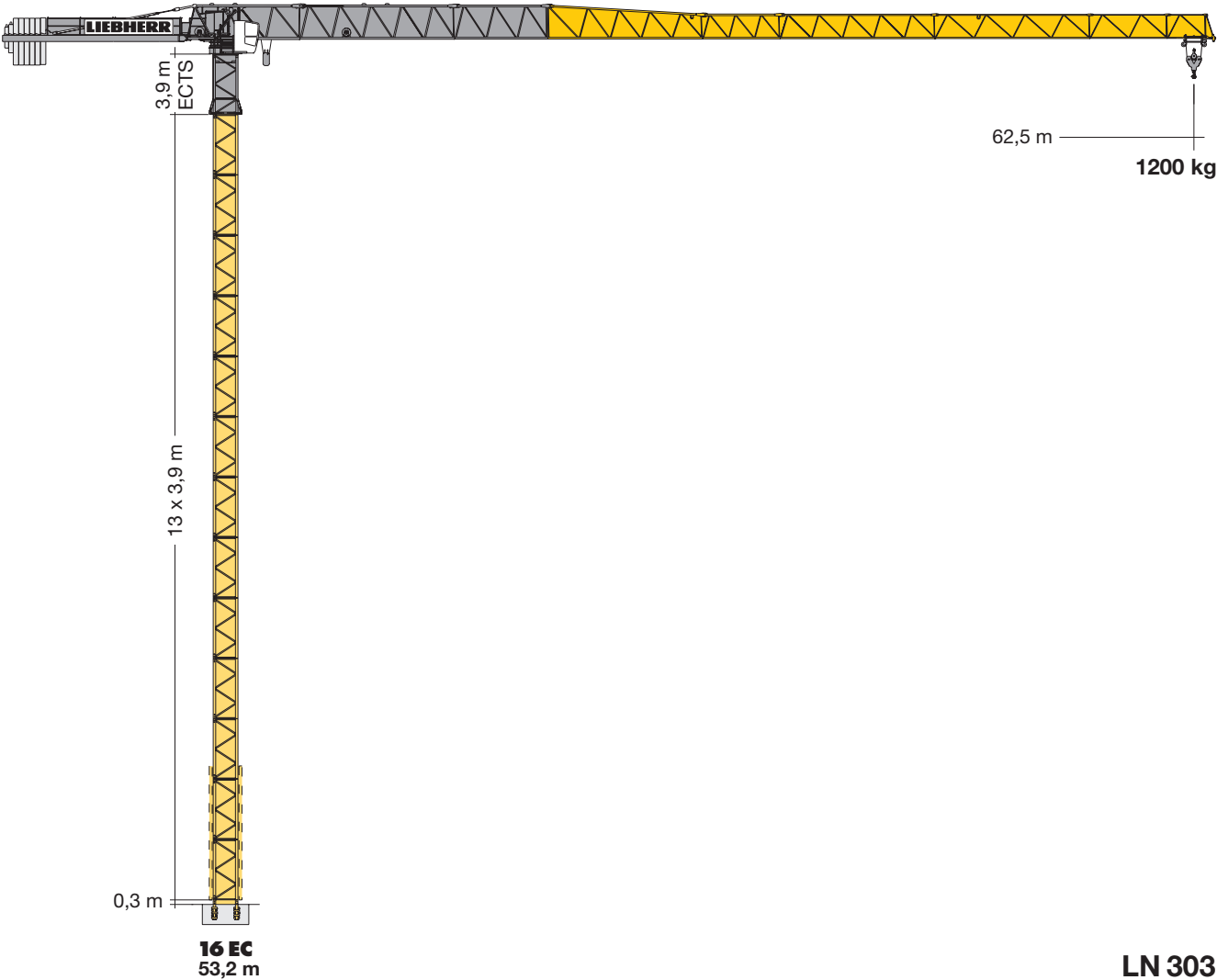

# LIEBHERR

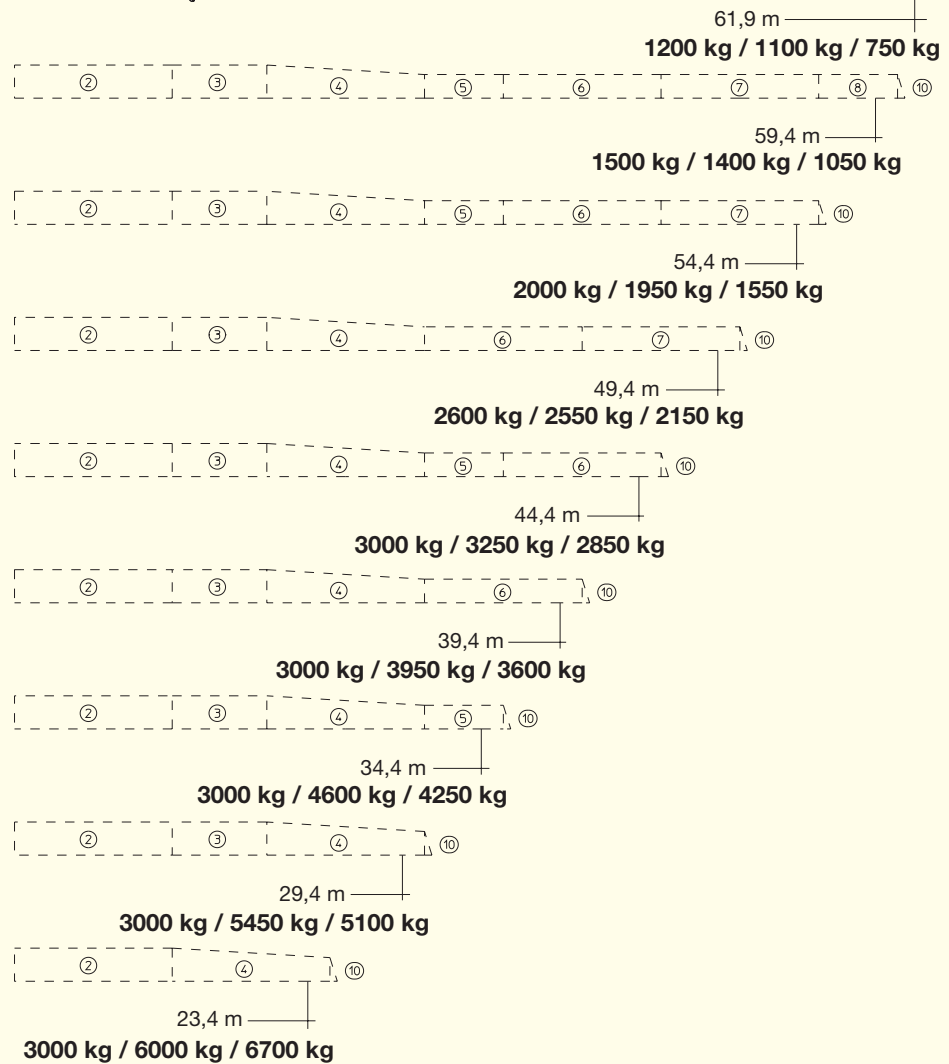
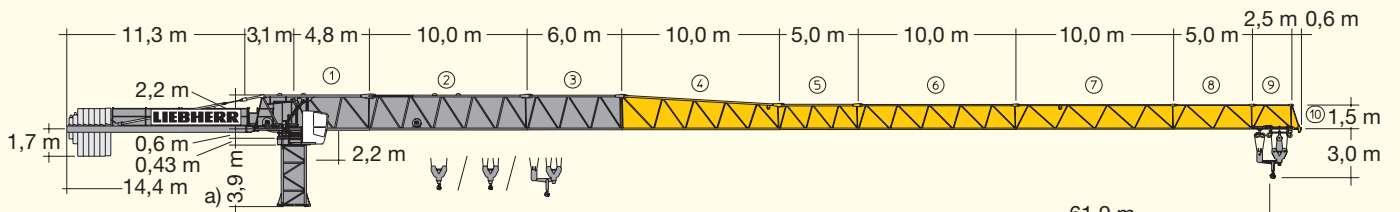

a) Tower section or climbing tower section

# Radius and capacity

m	r	m/kg	m/kg								
			24,0	30,0	35,0	40,0	45,0	50,0	55,0	60,0	62,5
62,5	(r = 63,9)	3,3-30,5 3000	3000	3000	2540	2160	1860	1630	1430	1270	1200
60,0	(r = 61,4)	3,3-34,4 3000	3000	3000	2940	2510	2170	1900	1680	1500	
55,0	(r = 56,4)	3,3-39,4 3000	3000	3000	3000	2950	2560	2250	2000		
50,0	(r = 51,4)	3,3-44,3 3000	3000	3000	3000	3000	2950	2600			
45,0	(r = 46,4)	3,3-45,0 3000	3000	3000	3000	3000	3000	3000			
40,0	(r = 41,4)	3,3-40,0 3000	3000	3000	3000	3000	3000				
35,0	(r = 36,4)	3,3-35,0 3000	3000	3000	3000						
30,0	(r = 31,4)	3,3-30,0 3000	3000	3000							
24,0	(r = 25,4)	3,3-24,0 3000	3000								

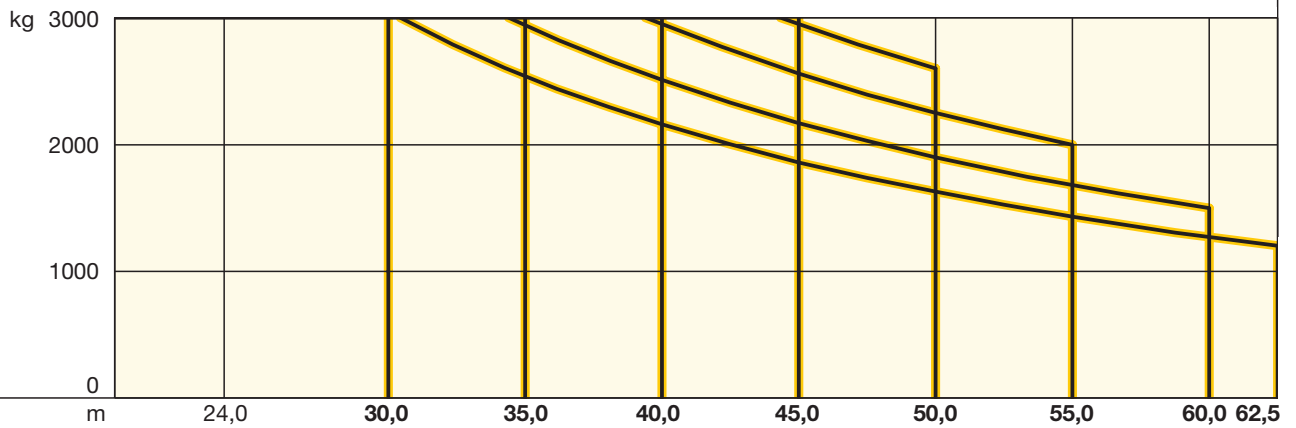

# Radius and capacity

m	r	m/kg	m/kg									
			20,0	24,0	30,0	35,0	40,0	45,0	50,0	55,0	60,0	62,5
62,5	(r = 63,9)	$\frac{3,3-16,4}{6000}$	4790	3880	2970	2450	2060	1770	1530	1330	1170	1100
60,0	(r = 61,4)	$\frac{3,3-18,5}{6000}$	5500	4460	3430	2850	2410	2070	1800	1580	1400	
55,0	(r = 56,4)	$\frac{3,3-21,6}{6000}$	6000	5320	4110	3430	2920	2520	2210	1950		
50,0	(r = 51,4)	$\frac{3,3-24,2}{6000}$	6000	6000	4690	3920	3350	2900	2550			
45,0	(r = 46,4)	$\frac{3,3-26,5}{6000}$	6000	6000	5210	4370	3740	3250				
40,0	(r = 41,4)	$\frac{3,3-27,8}{6000}$	6000	6000	5500	4610	3950					
35,0	(r = 36,4)	$\frac{3,3-27,7}{6000}$	6000	6000	5490	4600						
30,0	(r = 31,4)	$\frac{3,3-27,6}{6000}$	6000	6000	5450							
24,0	(r = 25,4)	$\frac{3,3-24,0}{6000}$	6000	6000								

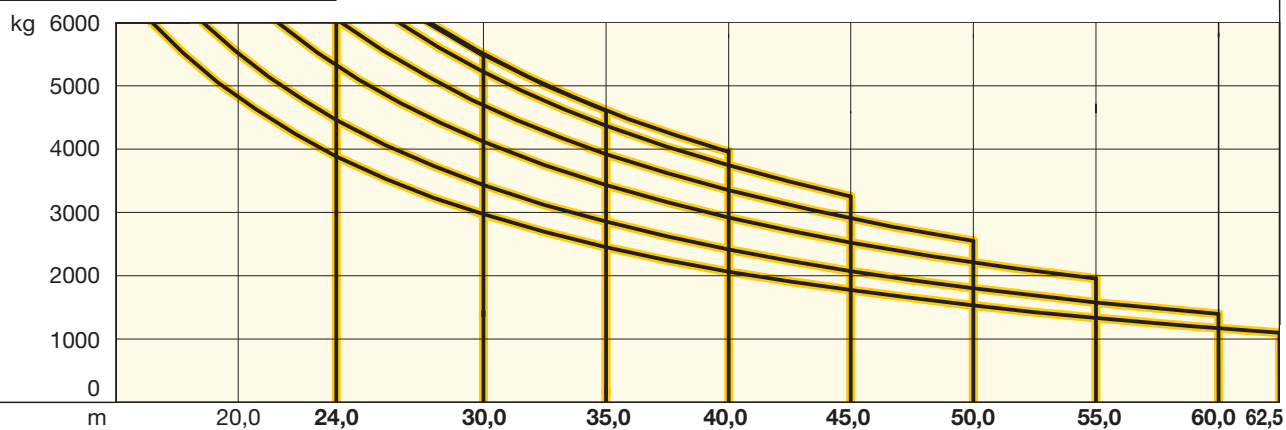

# Radius and capacity

m	r	m/kg	m/kg										
			15,0	20,0	25,0	30,0	35,0	40,0	45,0	50,0	55,0	60,0	61,9
61,9 (r = 63,9)	2,8-11,3 9000		6400	4490	3370	2630	2100	1710	1410	1170	970	810	750
59,4 (r = 61,4)	2,8-12,6 9000		7330	5180	3910	3080	2490	2050	1710	1440	1210	59,4m 1050	
54,4 (r = 56,4)	2,8-14,3 9000		8520	6050	4610	3650	2980	2480	2090	1780	54,4m 1550		
49,4 (r = 51,4)	2,8-16,0 9000		9000	6920	5290	4220	3460	2900	2460	49,4m 2150			
44,4 (r = 46,4)	2,8-17,5 9000		9000	7700	5910	4730	3900	3280	44,4m 2850				
39,4 (r = 41,4)	2,8-18,5 9000		9000	8220	6320	5070	4190	39,4m 3600					
34,4 (r = 36,4)	2,8-18,4 9000		9000	8170	6280	5040	34,4m 4250						
29,4 (r = 31,4)	2,8-18,2 9000		9000	8080	6210	29,4m 5100							
23,4 (r = 25,4)	2,8-18,2 9000		9000	8060	23,4m 6700								

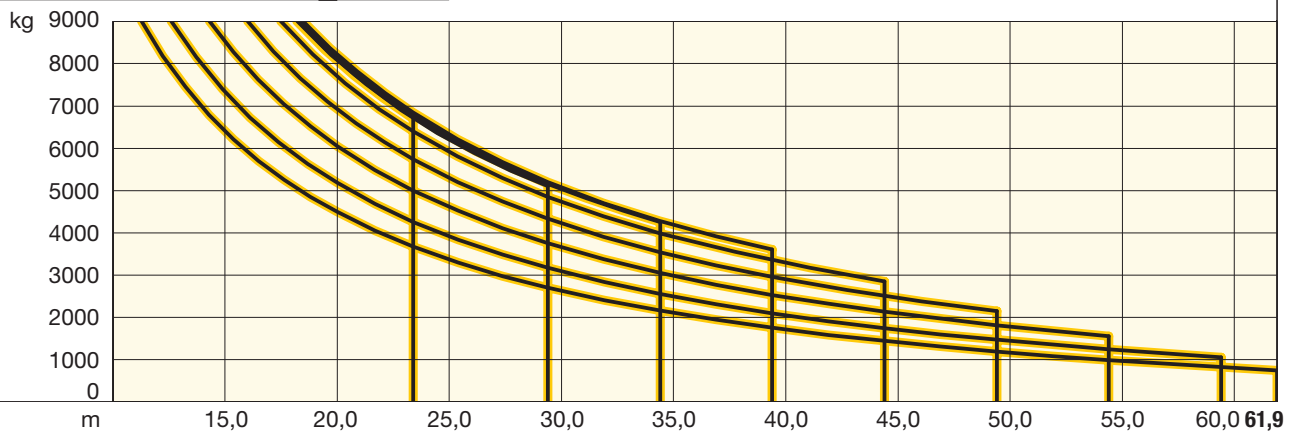

# Internal climbing Radius and tower height

		16EC		Shaft opening
n (pcs)	tower height	he (min. – max.)		Floor opening
9	50,7 <sup>1)</sup>	8,5 – 11,0		
8	46,8 <sup>1)</sup>	7,5 – 11,0		
7	42,9 <sup>1)</sup>	7,5 – 11,0		
6	39,0 <sup>1)</sup>	7,5 – 11,0		
5	35,1 <sup>1)</sup>	7,5 – 11,0		
4	m 31,2 <sup>1)</sup>	m	7,5 – 9,0	n

<sup>1)</sup> Tower heights for tower configuration on foundation anchors.  
n = not valid  
For Details please refer to the operating manual.

# Hoisting height

LN 303	16EC <sup>7)</sup>
13	53,2 <sup>2) 3) 6)</sup>
12	49,3 <sup>2) 3) 5)</sup>
11	45,4 <sup>2) 3) 4)</sup>
10	41,5 <sup>2)</sup>
9	37,6
8	33,7
7	29,8
6	25,9
5	22,0
4	18,1
3	14,2
2	10,3
1	6,4
0	2,5
	m

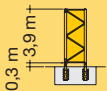

<sup>2)</sup>  All hoisting heights inclusive climbing tower section 16 EC 160 ECTS

<sup>3)</sup> 1 x 16 EC 160-240 TST-0390c

<sup>4)</sup> 1 x 16 EC 240 TS-0390c

<sup>5)</sup> 2 x 16 EC 240 TS-0390c

<sup>6)</sup> 3 x 16 EC 240 TS-0390c

<sup>7)</sup> The hoisting heights in 6-fall operation have to be reduced by 0,5 m.

Tower sections 16 EC 240 must be installed on the tower base. See operation manual for further details.

# External climbing<sup>10)</sup>

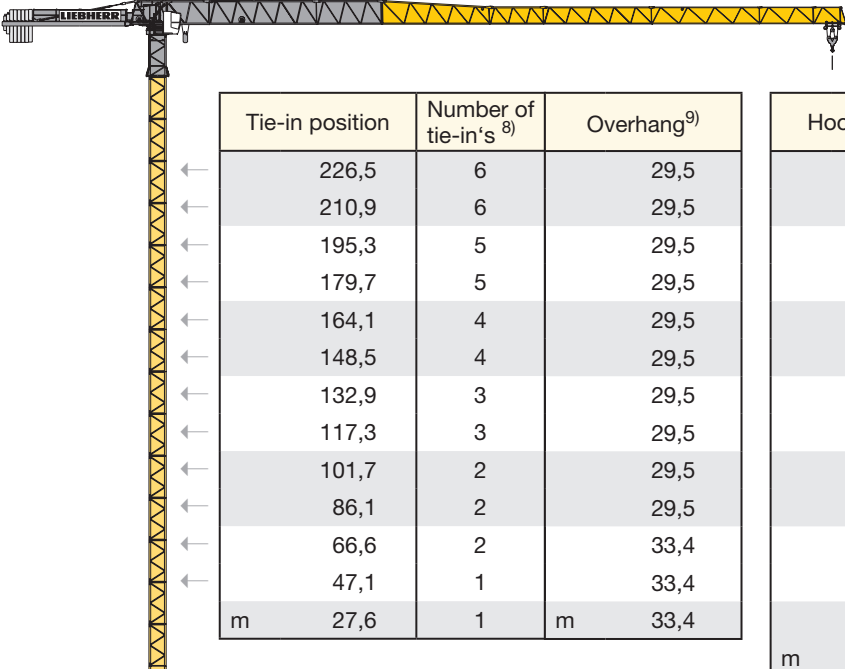











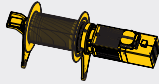
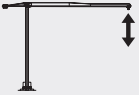



Tie-in position	Number of tie-in's <sup>8)</sup>	Overhang <sup>9)</sup>	Hook height
← 226,5	6	29,5	256,0
← 210,9	6	29,5	240,4
← 195,3	5	29,5	224,8
← 179,7	5	29,5	209,2
← 164,1	4	29,5	193,6
← 148,5	4	29,5	178,0
← 132,9	3	29,5	162,4
← 117,3	3	29,5	146,8
← 101,7	2	29,5	131,2
← 86,1	2	29,5	115,6
← 66,6	2	33,4	100,0
← 47,1	1	33,4	80,5
m 27,6	1	m 33,4	61,0
			m 41,5



<sup>8)</sup> Total number of tie-in's can be decreased by Liebherr project planning.

<sup>9)</sup> Tower height above last tie-in frame.

<sup>10)</sup> All data's calculated with 16 EC 160. Optimization by using 16 EC 240 possible.

# Driving units

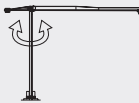

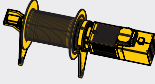
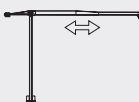











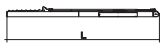



	↔ stepless																	
	kg		m/min		kg		m/min		kg		m/min							
24,0 kW FU WIW 230 MZ 426 <b>7 layers</b>  247,0 m / 123,0 m max. 288,0 m / 144,0 m / 82,0 m <sup>11)</sup>		3000	0 ↔ 38		6000	0 ↔ 19		9000	0 ↔ 13		1100	0 ↔ 91		2400	0 ↔ 46		3500	0 ↔ 30
30,0 kW FU WIW 240 MZ 410 <b>10 layers</b>  501,0 m / 250,0 m / 167,0 m <sup>11)</sup>		3000	0 ↔ 46		6000	0 ↔ 23		9000	0 ↔ 15		1000	0 ↔ 115		2400	0 ↔ 57		3500	0 ↔ 38

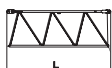

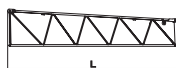



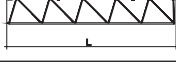



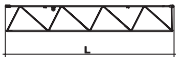





	0 ↔ 0,6 U/min.	2 x 5,0 kW FU	 <b>kVA</b>		24 kW FU	30 kW FU
	0 ↔ 60,0 m/min.	5,5 kW FU		39,0	44,0	

<sup>11)</sup> Further hoist load data: see instruction manual









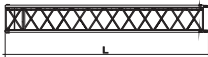

# Packing List

Erection weights: see instruction manual.







Upper part of crane			L (m)	B (m)	H (m)	kg	
Item	Qty.						
1	1	Slewing platform with slewing ring and slewing ring support 16 EC 		2,40	2,28	1,84	3400
2	1	Cabin with platform 		2,54	1,54	2,29	650
3	1	Counter-jib 		11,90	1,33	0,62	2700
4	1	Jib heel section 		7,85	2,12	2,45	① 3920
5	1	Intermediate jib section 		10,29	1,23	2,31	② 2180
6	1	Intermediate jib section 		6,26	1,15	2,25	③ 880
7	1	Intermediate jib section 		10,25	1,15	2,24	④ 1130
8	1	Intermediate jib section 		5,24	1,15	1,66	⑤ 540
9	1	Intermediate jib section 		10,21	1,15	1,63	⑥ 850

Item	Qty.			L (m)	B (m)	H (m)	kg	
10	1	Intermediate jib section			10,17	1,15	1,60	⑦ 640
11	1	Intermediate jib section			5,15	1,15	1,57	⑧ 260
12	1	Intermediate jib section			2,65	1,15	1,57	⑨ 150
13	1	Jib head section			1,04	1,17	1,80	⑩ 100
14	1	Trolley			1,62	1,36	0,78	180
15	1	Trolley			1,23	1,36	0,79	110
16	1	Hook			1,06	0,26	0,94	320
17	1	Hook and cross members			1,49	0,29	2,01	230











## Tower

18	1	Climbable tower section 16 EC 160 TS-0390c			4,19	1,73	1,68	1550
19	1	Tower section 16 EC 160 TS-1170			11,99	1,64	1,64	3620
20	1	Transition tower section 16 EC 160-240 TST-0390c			4,21	1,76	1,68	2100
21	1	Climbable tower section 16 EC 240 TS-0390c			4,21	1,76	1,68	2050
22	1	Tower section 16 EC 240 TS-1170			12,01	1,64	1,64	5050

## Climbing equipment

23	1	Climbing tower section 16 EC 160 ECTS-0390			4,19	2,11	2,11	1800
24	1	Guide section cpl. 16 EC 160 ECGS			8,83	3,39	4,13	4230
25	1	Hydraulic unit 16 ECP			2,37	1,24	0,81	670

## Climbing in the building

26	1	Internal climbing D-section 16 EC 240 ICDS-0390			4,21	1,76	1,93	2520
27	1	Hydraulic unit 16 ECP			2,37	1,24	0,81	670
28	1	Climbing cross member			1,65	0,24	0,76	340
29	1	Tower reinforcement			1,38	0,76	0,26	50
30	1	Guide frame 16 EC 240 ICGF			2,20	2,31	1,41	1030

Subject to alterations!

This information is supplied without liability.

TCS-001440-LBC-01 • LN 303 – EN 13001-HC1/S2 • BGL C.0.10.0140 • 12.16

Printed in Germany.