

Turmdrehkran

Tower Crane / Grue à tour / Gru a torre / Grúa torre
Guindaste de torre / Башенный поворотный кран

154 EC-H 10 FR.tronic®

154 EC-H 6 FR.tronic®

154 EC-H 6 Litronic®

▶ 154 EC-H 10 FR.tronic®

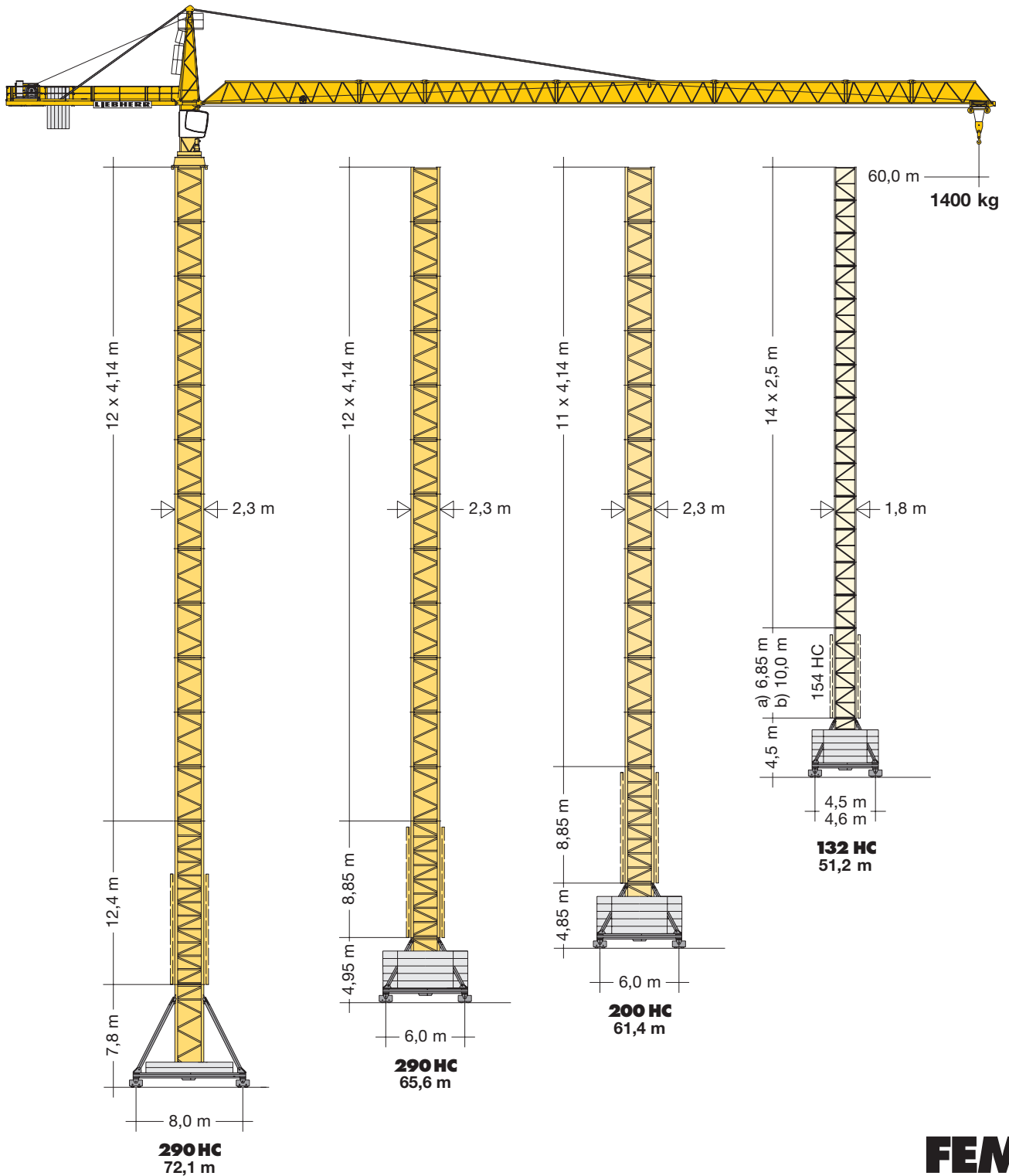

FEM

LIEBHERR

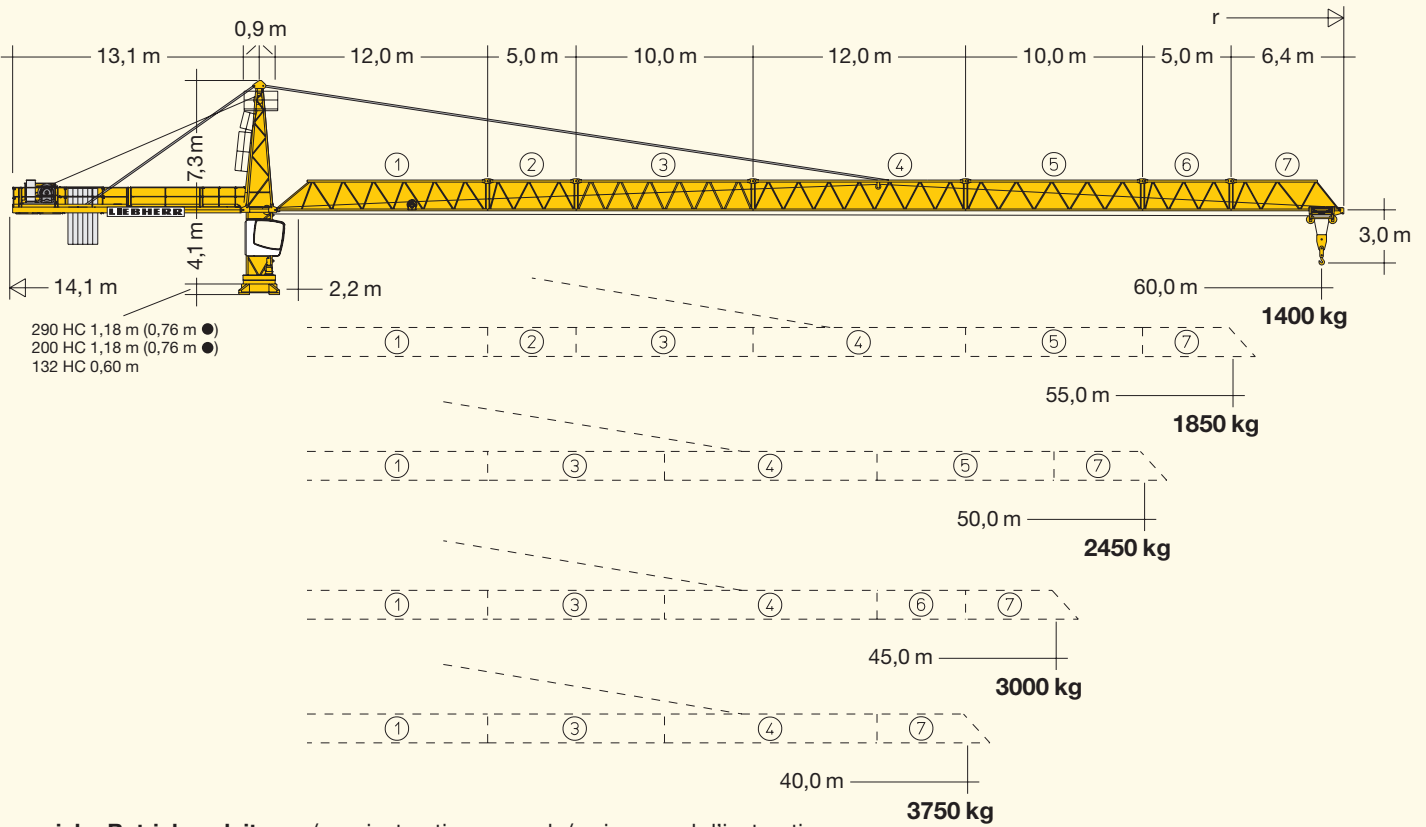

Hubhöhe Hoisting height / Hauteur sous crochet / Altezza di sollevamento Altura bajo gancho / Altura de montagem / Высота подъема

132 HC

15	-	-	-	-	-	-	46,3*	49,5*	-	-	-	-
14	48,0*	51,2*	47,5*	50,7*	-	-	43,8*	47,0*	-	-	-	-
13	45,5*	48,7*	45,0*	48,2*	42,6*	45,8*	41,3	44,5*	-	-	-	-
12	43,0	46,2*	42,5	45,7*	40,1	43,3*	38,8	42,0	-	-	-	-
11	40,5	43,7	40,0	43,2	37,6	40,8	36,3	39,5	37,7*	-	37,5*	-
10	38,0	41,2	37,5	40,7	35,1	38,3	33,8	37,0	35,2*	38,4*	35,0*	38,2*
9	35,5	38,7	35,0	38,2	32,6	35,8	31,3	34,5	32,7	35,9*	32,5	35,7*
8	33,0	36,2	32,5	35,7	30,1	33,3	28,8	32,0	30,2	33,4	30,0	33,2
7	30,5	33,7	30,0	33,2	27,6	30,8	26,3	29,5	27,7	30,9	27,5	30,7
6	28,0	31,2	27,5	30,7	25,1	28,3	23,8	27,0	25,2	28,4	25,0	28,2
5	25,5	28,7	25,0	28,2	22,6	25,8	21,3	24,5	22,7	25,9	22,5	25,7
4	23,0	26,2	22,5	25,7	20,1	23,3	18,8	22,0	20,2	23,4	20,0	23,2
3	20,5	23,7	20,0	23,2	17,6	20,8	16,3	19,5	17,7	20,9	17,5	20,7
2	18,0	21,2	17,5	20,7	15,1	18,3	13,8	17,0	15,2	18,4	15,0	18,2
1	15,5	18,7	15,0	18,2	12,6	15,8	11,3	14,5	12,7	15,9	12,5	15,7
0	a) 13,0 b) 16,2	a) 12,5 b) 15,7	a) 10,1 b) 13,3	a) 8,8 b) 12,0	a) 10,2 b) 13,4	a) 10,0 b) 13,2						

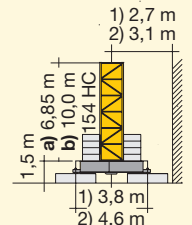
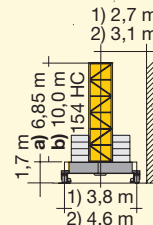
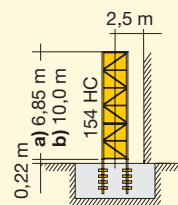
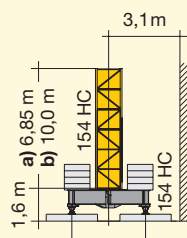
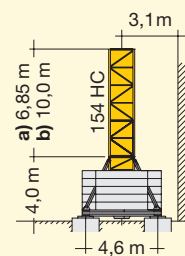
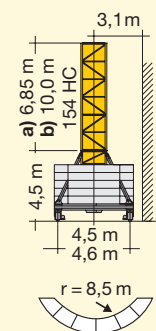

*  **Weitere Hubhöhen, Auslegerlängen sowie Klettern im Gebäude auf Anfrage.** / Further hoist heights and lengths as well as climbing inside the building on request. / Autres hauteurs sous crochet et longueurs de flèche ainsi que hissage dans le bâtiment sur demande. / Ulteriori altezze gancio, lunghezze braccio così come telescopaggio all'interno dell'edificio: su richiesta. / Para alturas bajo gancho superiores, otros alcances y trepado en el interior del edificio, consultar. / Outras alturas de elevação, comprimentos de lança e subida no edifício: sob consulta. / Другие высоты подъема, длины стрелы и самоподъем в здании – по запросу.

Ausladung und Tragfähigkeit

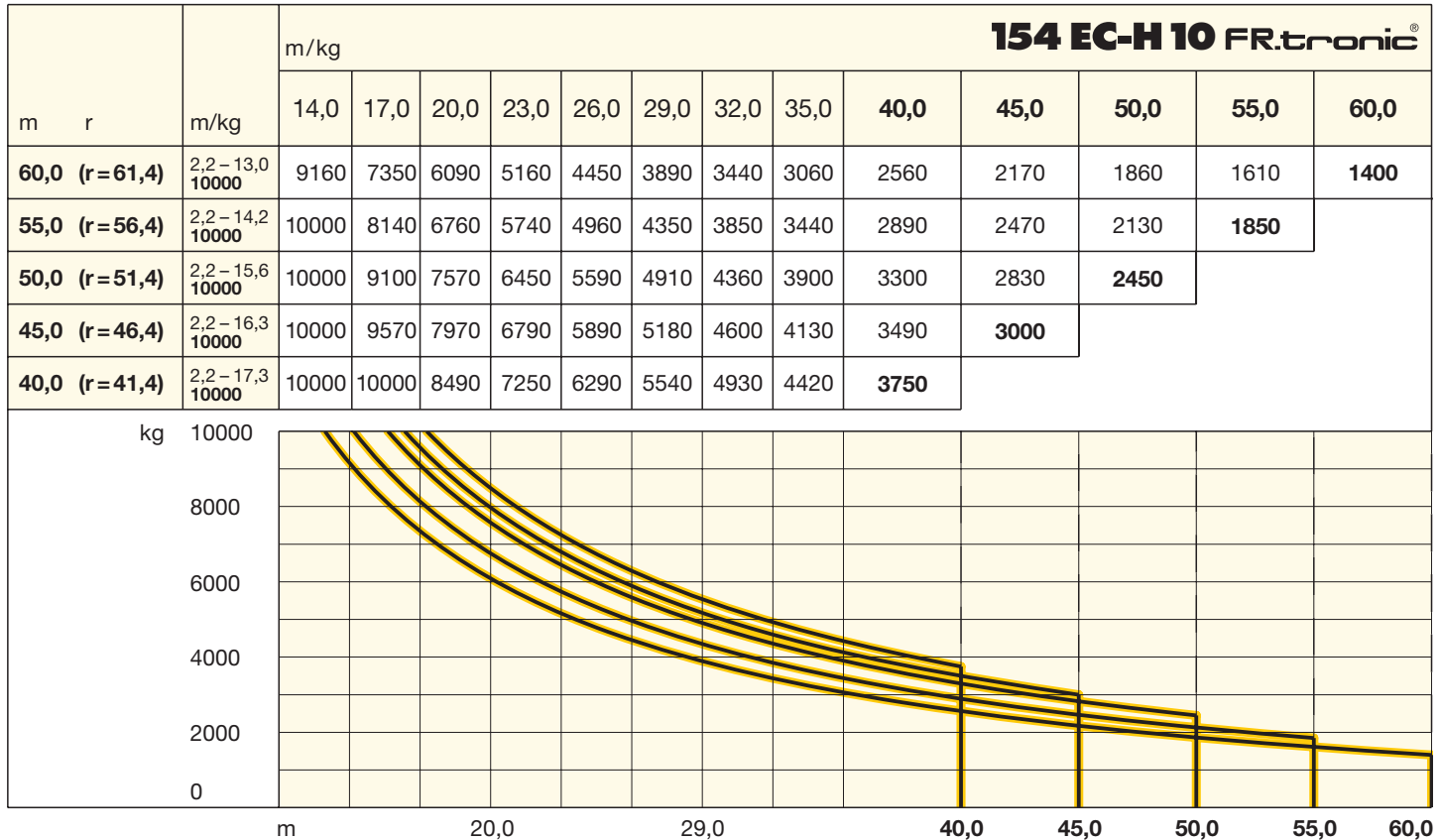

Radius and capacity / Portée et charge / Sbraccio e portata
Alcances y cargas / Alcance e capacidade de carga / Вылет и грузоподъемность



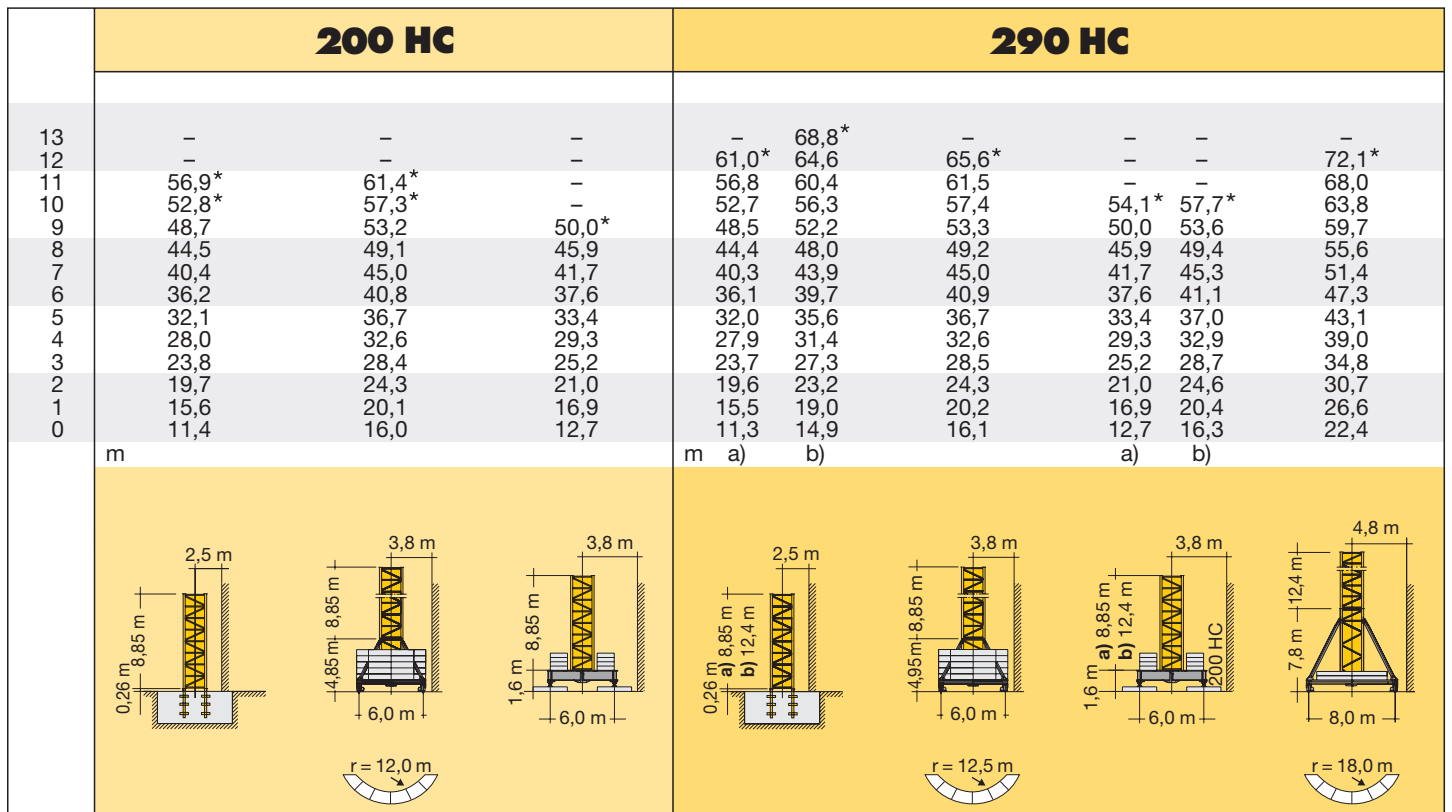

Hubhöhe

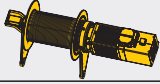
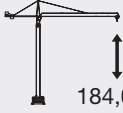
Hoisting height / Hauteur sous crochet / Altezza di sollevamento
Altura bajo gancho / Altura de montagem / Высота подъема



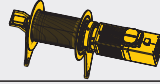
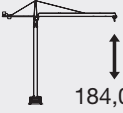

	↔ stufenlos / stepless / régl. continu regl. progressiva / sin escalones / sem degraus бесступенчатый kg m/min
37 kW FU WIW 250 MZ 402 6 Lagen Layers Couches Avvolgimenti Camadas Capas Слоёв  184,0 m	 10000 0 ↔ 19 1150 0 ↔ 80
max. 261,0 m**	

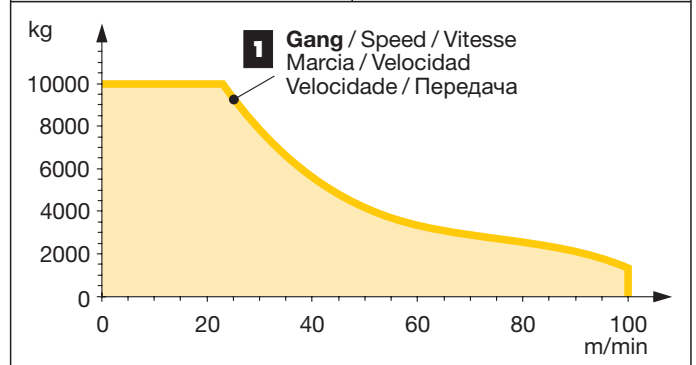
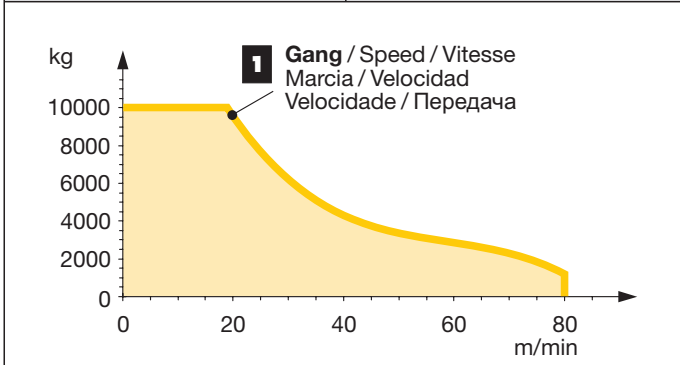



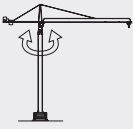
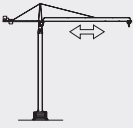
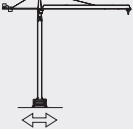





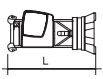

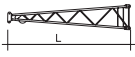

















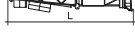

	↔ stufenlos / stepless / régl. continu regl. progressiva / sin escalones / sem degraus бесступенчатый kg m/min
45 kW FU WIW 260 MZ 401 6 Lagen Layers Couches Avvolgimenti Camadas Capas Слоёв  184,0 m	 10000 0 ↔ 23 1200 0 ↔ 100
max. 261,0 m**	



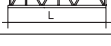

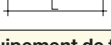









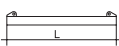

** Weitere Hublastdaten: siehe Betriebsanleitung. / Further hoist load data: see instruction manual. / Autres données de la charge de levage: voir manuel d'instruction. / Altri dati sui carichi sollevati: consultare il manuale d'istruzione. / Alturas bajo grancho superiores según manual. / Outras tabelas de carga: consultar manual de instruções. / Другие данные по весу поднимаемых грузов: см. инструкцию по эксплуатации

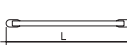
	0 ↔ 0,8 sl./min tr./min	1 x 7,5 kW FU
	0 ↔ 100,0 m/min	5,5 kW FU
	25,0 m/min	2 x 4,0 kW (132 HC) 2 x 7,5 kW (290 HC) 2 x 5,5 kW (200 HC)
	kVA	37 kW FU 45 kW FU 47,0 54,0

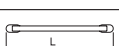
Montagegewichte: siehe Betriebsanleitung. / Erection weights: see instruction manual. / Poids de montage: voir manuel de service. / Pesì di montaggio: vedere manuale d'uso. / Peso para el montaje: según manual. / Pesos de montagem: veja-se as instruções p. uso. / Масса монтируемых частей: см. инструкцию по эксплуатации.

Kranoberteil		Upper part of crane / Partie supérieure de grue / Parte superiore della gru	Parte superior grúa / Parte superior do guindaste / Верхняя часть крана	L (m)	B (m)	H (m)	kg*							
Pos.	Anz.	Kabine mit Drehbühne / Cabin with slewing platform Cabine avec ensemble mât-cabine / Cabina con piattaforma girevole / Plataforma de giro / Cabina com plataforma giratória / Кабина с поворотной платформой			132 HC	5,15	2,44	2,48	6900					
Rep.	Qty.									200 HC	6,00	2,74	2,65	7500
Voce.	Qta.									290 HC	6,00	2,74	2,65	7500
Pos.	Cant.													
Ref.	Cant.													
Pos.	Кол-во													
1	1													
2	1	Turmspitze / Tower head section / Porte-flèche Testa porta-braccio / Cabeza de torre / Cabeça de arpaio de lança / Оголовок башни			7,30	1,48	1,70	1870						
3	1	Hubwerkseinheit / Hoist gear unit / Treuil de levage Gruppo meccanismo sollevamento / Mecanismo de elevación / Grupo de mecanismo elevatório / Блок грузовой лебедки			2,20	2,34	1,70	2700						
4	1	Gegenausleger / Counter-jib / Contre-flèche Controffaccia / Contrapluma / Contra-lança / Консоль противовеса			13,11	2,42	0,57	3000						
5	1	Gegenausleger mit Hubwerkseinheit / Counter-jib with hoist gear unit / Contre-flèche avec treuil de levage Controbraccio con gruppo meccanismo sollevamento / Contrapluma con mecanismo de elevación / Contra-lança com grupo de mecanismo elevatório / Консоль противовеса с блоком грузовой лебедки			13,11	2,42	2,20	7200						
6	1	Ausleger-Anlenkstück / Jib heel section / Pied de flèche Sezione articolata braccio / Pluma tramo primero / Base articulada de lança / Корневая секция стрелы			12,24	1,58	1,79	① 2050						
7	1	Ausleger-Zwischenstück / Intermediate jib section Élément intermédiaire de flèche / Sezione intermedia braccio / Tramo intermedio pluma / Peça complementar da lança / Промежуточная секция стрелы			12,30	1,25	1,70	④ 1640						
8	2	Ausleger-Zwischenstück / Intermediate jib section Élément intermédiaire de flèche / Sezione intermedia braccio / Tramo intermedio pluma / Peça complementar da lança / Промежуточная секция стрелы			10,30	1,25	1,70	③ 1130 ⑤ 750						
9	2	Ausleger-Zwischenstück / Intermediate jib section Élément intermédiaire de flèche / Sezione intermedia braccio / Tramo intermedio pluma / Peça complementar da lança / Промежуточная секция стрелы			5,25	1,25	1,68	⑥ 370 ② 630						
10	1	Ausleger-Kopfstück / Jib head section / Pointe de flèche Punta braccio / Tramo punta de pluma / Cabeça de lança / Концевая секция стрелы			6,51	1,43	1,88	⑦ 500						
11	1	Laufkatze und Lasthaken / Trolley and hook Chariot de distribution et crochet / Carrello con gancio / Carrito y gancho / Carro de ponte e gancho / Грузовая тележка и грузовой крюк			1,90	1,42	1,38	930						
12	1	Drehbühne und Turmspitze / Slewing platform and tower head section / Ensemble mât-cabine et porte-flèche Piattaforma girevole e cuspidè / Plataforma de giro y cabeza torre / Plataforma giratória e cabeça de torre / Поворотная платформа и оголовок башни			132 HC 12,20 200 HC 12,70 290 HC 12,70	2,45 2,74 2,74	2,62 2,65 2,65	8770 9370 9370						
13	1	Ausleger- und Gegenausleger-Abspannung / Jib and counter-jib suspension Haubanage de flèche et de contre-flèche / Attrezzatura di ancoraggio di braccio e controbraccio / Tirantes de sost en pluma y contrapluma / Grupo de ancoragem de lança e contra-lança / Расчал стрелы и консоли противовеса			8,20 5,87	0,55 0,20	0,12 0,16	1170 380						
Turm		Tower / Mât / Torre Torre / Torre / Башня												
14	13	Turmstück / Tower section Élément de mât / Elemento di torre Tramo torre / Torre / Башенная секция			132 HC 2,50 200 HC 4,14 290 HC 4,14	1,80 2,30 2,30	1,80 2,30 2,30	1090 2240 2300						
15	7	Turmstück lang / Long tower section / Élément de mât long Elemento di torre, lungo / Tramo de torre largo Peça de torre, comprida / Башенная секция, длинная			132 HC 5,00 132 HC 10,00 132 HC 12,50	1,80 1,80 1,80	1,80 1,80 1,80	1830 3430 4200						
16	1	Grundturmstück / Base tower section / Mât de base Elemento di torre base / Tramo base Peça de base de torre / Секция основания			154 HC 6,85 154 HC 10,00 200 HC 8,85 290 HC 8,85 (12,42)	1,80 1,80 2,30 2,30 (2,30)	1,80 1,80 2,30 2,30 (2,30)	2930 3990 4280 4830 (7940)						
Klettereinrichtung		Climbing equipment / Equipement de télescopage / Attrezzatura per allungamento della gru Equipo de trepado / Acesórios p. subida no edifício / Обойма наращивания												
17	1	Führungsstück kpl. / Guide section cpl. / Cage télescopique cpl. Gabbia di sopraelevazione compl. Torre de montaje completa / Peça de guia compl. Направляющая секция в сб.			132 HC 6,45 132 HC 9,60 200 HC 8,39 290 HC 8,39	2,10 2,10 2,68 2,68	2,42 2,42 2,58 (3,04) 2,58 (3,04)	2660 4410 5100 5100						
18	1	Hydraulikanlage, Stütz- und Klettertraverse / Hydraulic unit, supporting and climbing cross members / Système hydraulique avec traverses d'appui et de télescopage Sistema idraulico, traversa di appoggio e allungamento gru Sistema hidráulico con traviesa de apoyo y trepado / Instalação hidráulica, travessa de apoio e subida / Гидроагрегат, стойка-упор и траверса обоймы наращивания			132 HC 2,87 200 HC 2,30 290 HC 2,30	2,12 1,25 1,25	1,06 1,00 1,00	1050 1150 1150						

Pos. Item Rep. Voce Pos. Ref. Pos.	Anz. Qty. Qte. Qta. Cant. Cant. Кол-во				L (m)	B (m)	H (m)	kg*	
Unterwagen Undercarriage / Châssis / Carro Carro con mástil / Carro de guindaste / Опорная рама									
19	2	Fahrschemel mit Antrieb / Rail bogie with drive Bogie moteur / Telaio con gruppo propulsore Caja rodillo motriz / Quadro sem grupo de propulsão Подрамник с приводом			132 HC 200 HC 290 HC	1,38 1,46 1,63 (1,46)	0,88 0,84 0,92 (0,84)	0,87 0,87 0,95 (0,87)	900 920 1690 (920)
20	2	Fahrschemel ohne Antrieb / Rail bogie without drive Bogie fou / Telaio senza gruppo propulsore / Caja rodillo conducido / Quadro com grupo de propulsão Подрамник без привода			132 HC 200 HC 290 HC	1,17 1,15 1,37 (1,15)	0,60 0,60 0,62 (0,60)	0,87 0,87 0,95 (0,87)	860 880 1340 (880)
21	1	Tragholm lang / Long support arm / Longeron long Longherone lungo / Brazo soporte largo / Travessa comprida / Несущая балка, длинная			132 HC 200 HC 290 HC	7,12 9,10 9,10 (11,95)	0,78 0,82 0,80 (0,82)	0,65 0,74 0,80 (0,80)	950 1350 1650 (2200)
22	2	Tragholm kurz / Short support arm / Longeron court Longherone corto / Brazo soporte corto / Travessa curta / Несущая балка, короткая			132 HC 200 HC 290 HC	3,45 4,41 4,45 (5,58)	0,56 0,62 0,77 (0,65)	0,55 0,71 0,77 (0,77)	408 615 800 (1035)
23	2 + 2	Randträger / Border support / Traverse Supporti base / Traviesa / Apoio de bordo Стяжная балка			132 HC 200 HC 290 HC	4,02 5,48 – 5,46 5,46 – 5,40 (7,52 – 7,46)	0,35 0,11 – 0,17 0,11 – 0,18 (0,10 – 0,17)	0,12 0,16 – 0,38 0,16 – 0,38 (0,10 – 0,38)	95 118 – 454 175 – 525 (366 – 912)
24	4	Stützholm / Support strut / Hauban de châssis Correnti di appoggio / Tirante vertical / Travessa de apoio / Опорный подкос			132 HC 200 HC 290 HC	3,78 4,23 4,14 (6,55)	0,15 0,17 0,18 (0,22)	0,22 0,25 0,25 (0,25)	200 275 320 (600)
25	1	Unterwagen-Turmstück / Undercarriage tower section / Mât de châssis / Elemento di torre del carro Tramo de carro / Peça de torre do chassis Опорная башенная секция			132 HC 200 HC 290 HC	3,50 3,73 3,73 (6,70)	2,06 2,52 2,62 (2,53)	2,06 2,52 2,62 (2,53)	1320 1950 2550 (3800)
26	1	Stapel Aufstiege und Podeste / Bundle of ladders and platforms / Faisceau d'échelles et de plates-formes / Serie di scale e rampe / Paquete de escaleras y plataformas / Escadas e patamares / Лестницы и площадки			132 HC	3,50	1,20	1,00	1000
27	1	Kiste mit Kleinteilen / Crate with small parts / Caisse contenant des accessoires / Cassa con accessori / Caja con accesorios Caixa de acessórios / Ящик с мелкими деталями				2,00	1,00	1,00	2000

() **Angaben in Klammern gelten für 8 m-Unterwagen.** / The data in brackets are valid for an undercarriage of 8 m. / Les données techniques indiquées entre parenthèses sont valables pour un châssis de 8 m. / Caratteristiche in (...) valgono per carro di 8 m. / Los datos entre paréntesis son válidos para carro de 8 m. / Características em (...) válidas pelo chassis de 8 m. / Данные в скобках относятся к 8-метровой опорной раме

* **Einzelgewichte.** / Single weights. / Poids individuels. / Singoli pesi. / Pesos unitarios. / Pesos de peças componentes. / Индивидуальный вес.

Konstruktionsänderungen vorbehalten! / Subject to alterations! / Sous réserves de modifications! / Riservato il diritto di modifiche strutturali!
¡Sujeto a modificaciones! / Salvo modificação da construçao! / Права на внесение конструкторских изменений сохраняются!

Sämtliche Angaben erfolgen ohne Gewähr. / This information is supplied without liability. / Ces renseignements sont sans garantie. / Tutte le indicazioni fornite senza garanzia. / Declinamos toda responsabilidad derivada de la información proporcionada. / Declinamos qualquer responsabilidade quanto à informação fornecida. / Все данные указаны без обязательств.

121 P – 3782 FEM (Section 1) – Krangruppe A3 • 04.10 / 7

Printed in Germany.