

# DIESEL GENERATOR SET

## MTU 12V2000 DS1000

### STANDBY POWER: 1010 KVA

380V - 415V/50 Hz/Air Charge Air Cooling



Optional equipment and finishing shown. Standard may vary.

## PRODUCT HIGHLIGHTS

### // Benefits

- Low fuel consumption
- Optimized system integration ability
- High reliability and availability of power
- Long maintenance intervals
- Optimized ratio between size and power
- Wide operating range without derating

### // MTU Onsite Energy is a single-source supplier

### // Global product support

### // Standards

- Engine-generator set is designed and manufactured in facilities certified to standards ISO 2008:9001 and ISO 2004:14001
- Generator set complies to G3 according to ISO 8528
- Generator meets NEMA MG1, BS5000, ISO, DIN EN and IEC standards
- NFPA 110

### // Power Rating

- System rating: 1010 kVA
- Accepts rated load in one step per NFPA 110
- Generator set complies to G3 according to ISO 8528-5
- Generator set exceeds load steps according to ISO 8528-5

### // Performance Assurance Certification (PAC)

- Engine-generator set tested to ISO 8528-5 for transient response
- 85% load factor for standby power applications
- Verified product design, quality and performance integrity
- All engine systems are prototype and factory tested

### // Complete range of accessories available

- Control panel
- Circuit breaker/power distribution
- Fuel system
- Fuel connections with shut-off valve mounted to base frame
- Starting/charging system
- Exhaust system
- Mechanical radiator
- Container and Canopy

### // Emissions

- Fuel consumption optimized

### // Certifications

- CE certification option
- German Grid Code Certification (BDEW) option

APPLICATION DATA<sup>①</sup>

## // Engine

	Fuel consumption optimized	
Manufacturer		MTU
Model		12V2000G86F
Type		4-cycle
Arrangement		12V
Displacement:	l	26.8
Bore:	mm	135
Stroke:	mm	156
Compression ratio		17.5
Rated speed:	rpm	1500
Engine governor		ADEC
Speed regulation		± 0.25%
Max power:	kWm	887
Mean effective pressure:	bar	26.5
Air cleaner		Dry

## // Fuel System

Maximum fuel lift:	m	5
Total fuel flow:	l/min	30

// Fuel Consumption<sup>②</sup>

	l/hr
At 100% of power rating:	203.0
At 75% of power rating:	150.7
At 50% of power rating:	105.3

## // Lube oil system

Total oil system capacity:	l	80
Max. lube oil temperature (alarm):	°C	103
Max. lube oil temperature (shutdown):	°C	105
Min. lube oil pressure (alarm):	bar	4.5
Min. lube oil pressure (shutdown):	bar	4

## // Combustion Air Requirements

	Fuel consumption optimized	
Combustion air volume:	m <sup>3</sup> /s	1.03
Max. air intake restriction:	mbar	40

## // Cooling/Radiator System

Coolant flow rate (HT circuit):	m <sup>3</sup> /h	31.6
Heat rejection to coolant:	kW	330
Heat rejection to charge air:	kW	200
Heat radiated to ambient:	kW	35
Fan power for mech. radiator (40°C):	kWm	34
Fan power for mech. radiator (50°C):	kWm	51.1
Air flow required for mech. radiator (40°C) cooled unit:	m <sup>3</sup> /min	969
Air flow required for mech. radiator (50°C) cooled unit:	m <sup>3</sup> /min	1328
Engine coolant capacity (without cooling equipment):	l	63
Radiator coolant capacity (40°C):	l	59
Radiator coolant capacity (50°C):	l	140
Max. coolant temperature (warning):	°C	102
Max. coolant temperature (shutdown):	°C	105

## // Exhaust System

Exhaust gas temp. (after turbocharger):	°C	520
Exhaust gas volume:	m <sup>3</sup> /s	2.72
Maximum allowable back pressure:	mbar	50
Minimum allowable back pressure:	mbar	30

## // Generator

Protection class	IP23
Insulation class	H
Voltage regulation (steady state)	± 0.25%
Rado interference class	N

① All data refers only to the engine and is based on ISO standard conditions (25°C and 100m above sea level).

② Values referenced are in accordance with ISO 3046-1. Conversion calculated with fuel density of 0.83 g/ml.  
All fuel consumption values refer to rated engine power.

## STANDARD AND OPTIONAL FEATURES

### // System Ratings (kW/kVA)

Generator model	Voltage	with mechanical radiator		
		kWeI	kVA*	AMPS
Basic: Marathon 575RSL7180	380 V	808	1010	1535
Advanced: Marathon 575RSL7181	400 V	808	1010	1458
(Low voltage Marathon standard)	415 V	808	1010	1405
Basic: Marathon 740RSL7182	380 V	808	1010	1535
Advanced: Marathon 740RSL7183	400 V	808	1010	1458
(Low voltage Marathon oversized)	415 V	808	1010	1405
Leroy Somer LSA 49.1 L11	380 V	808	1010	1535
(Low voltage Leroy Somer)	400 V	808	1010	1458
	415 V	808	1010	1405
Leroy Somer LSA 50.2 M6	380 V	808	1010	1535
(Low voltage Leroy Somer oversized)	400 V	808	1010	1458
	415 V	808	1010	1405

\*  $\cos \phi = 0,8$

### // Engine

- 4-Cycle
- Standard single stage air filter
- Oil drain extension & shut-off valve
- Full flow oil filters
- Closed crankcase ventilation
- ADEC electronic isochronous engine governor
- Common rail fuel injection
- Dry exhaust manifold
- Electric starting motor (24V)
- Fuel consumption optimized engine

### // Generator

- NEMA MG1, BS5000, ISO, DIN EN and IEC standards
- Self-ventilated
- Superior voltage waveform
- Solid state, volts-per-Hertz regulator
- Ingress protection IP 23
- 3 phase voltage sensing
- 3% maximum harmonic content
- 2/3 pitch stator windings
- No load to full load regulation
- $\pm 0.25\%$  voltage regulation no load to full load
- Brushless alternator with brushless pilot exciter
- 4 pole, rotating field
- Sustained short circuit current of up to 250% of the rated current for up to 10 seconds (Marathon generator)
- Sustained short circuit current of up to 300% of the rated current for up to 10 seconds (Leroy Somer generator)
- Marathon low voltage generator
- Leroy Somer generator
- Oversized generator

## STANDARD AND OPTIONAL FEATURES, CONTINUATION

### // Cooling System

- Jacket water pump
- Thermostat(s)
- Air charge air cooling
- Mechanical radiator
- Jacket water heater

### // Control Panel

- Pre-wired control cabinet for easy application of customized controller (V1+)
- Island operation (V2)
- Automatic mains failure operation with ATS (V3a)
- Automatic mains failure operation incl. control of generator and mains breaker (V3b)
- Island parallel operation of multiple gensets (V4)
- Automatic mains failure operation with short (< 10s) mains parallel overlap synchronization (V5)
- Mains parallel operation of a single genset (V6)
- Mains parallel operation of multiple gensets (V7)
- Basler controller
- Deif controller
- Complete system metering
- Digital metering
- Engine parameters
- Generator protection functions
- Engine protection
- SAE J1939 engine ECU communications
- Parametrization software
- Multilingual capability
- Multiple programmable contact inputs
- Multiple contact outputs
- Event recording
- IP 54 front panel rating with integrated gasket
- Different expansion modules
- Remote annunciator
- Daytank control
- Generator winding temperature monitoring
- Generator bearing temperature monitoring
- Differential protection with multi-function protection relay
- Modbus RTU-TCP gateway

### // Circuit Breaker/Power Distribution

- 3-pole circuit breaker
- 4-pole circuit breaker
- Manual-actuated circuit breaker
- Electrical-actuated circuit breaker
- Base frame mounted circuit breaker
- Stand-alone circuit breaker in separate switch box

### // Fuel System

- Flexible fuel connectors mounted to base frame
- Fuel filter with water separator
- Switchable fuel filter with water separator
- Fuel cooler

## STANDARD AND OPTIONAL FEATURES, CONTINUATION

---

### // Starting/Charging System

- |   |  |
|---|--|
| <input checked="" type="checkbox"/> 24V starter | <input type="checkbox"/> Battery charger   |
| <input type="checkbox"/> Starter batteries      | <input type="checkbox"/> Redundant starter |

### // Mounting System

- |   |   |   |
|---|---|---|
| <input checked="" type="checkbox"/> Welded base frame | <input checked="" type="checkbox"/> Resilient engine and generator mounting | <input checked="" type="checkbox"/> Modular base frame design |
|---|---|---|

### // Enclosures and Containers

- |                                 |  |
|---------------------------------|--|
| <input type="checkbox"/> Canopy | <input type="checkbox"/> 20 foot container |
|---------------------------------|--|

### // Exhaust System

- |   |   |
|---|---|
| <input type="checkbox"/> Exhaust bellows with connection flange           | <input type="checkbox"/> Exhaust silencer with 40 dB(A) sound attenuation |
| <input type="checkbox"/> Exhaust silencer with 10 dB(A) sound attenuation | <input type="checkbox"/> Y-connection-pipe                                |
| <input type="checkbox"/> Exhaust silencer with 30 dB(A) sound attenuation |   |

## WEIGHTS AND DIMENSIONS

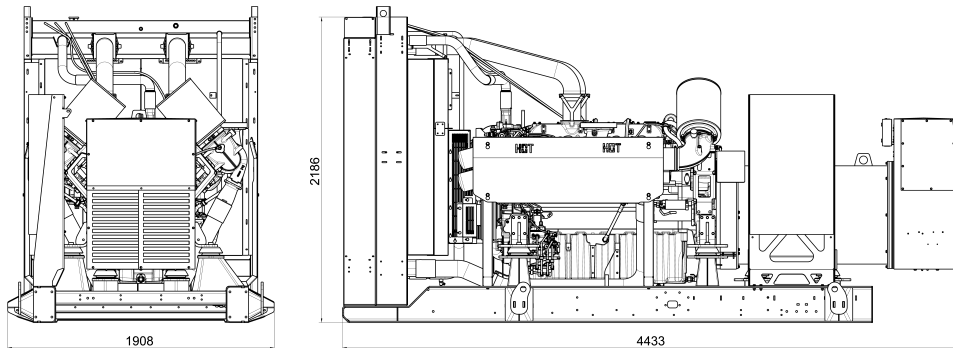

Drawing above for illustration purposes only, based on a standard open power 400 Volt engine-generator set. Lengths may vary with other voltages. Do not use for installation design. See website for unit specific template drawings.

### System

Open Power Unit (OPU)

### Dimensions (L x W x H)

4440 x 1910 x 2190 mm

### Weight (dry/less tank)

6260 kg

Weights and dimensions are based on open power units and are estimates only. Consult the factory for accurate weights and dimensions for your specific engine-generator set.

## SOUND DATA

// Consult your local MTU Onsite Energy distributor for sound data.

## EMISSIONS DATA

// Consult your local MTU Onsite Energy distributor for emissions data.

## RATING DEFINITIONS AND CONDITIONS

// Standby ratings apply to installations served by a reliable utility source. The standby rating is applicable to varying loads for the duration of a power outage. No overload capability for this rating. Ratings are in accordance with ISO 8528-1, ISO-3046-1, BS 5514 and AS 2789. Average Load Factor:  $\leq 85\%$ . Operating hours/year: max. 500.

// Deration factor:

Altitude: Consult your local MTU Onsite Energy Power Generation distributor for altitude derations.

Temperature: Consult your local MTU Onsite Energy Power Generation distributor for temperature derations.

Rated power is available up to 40°C and 400m above sea level.

Materials and specifications subject to change without notice.

MTU Onsite Energy

A Rolls-Royce Power Systems Brand

[www.mtuonsiteenergy.com](http://www.mtuonsiteenergy.com)