

DIESEL GENERATOR SET

MTU 12V2000 DS825

PRIME POWER: 750 KVA

380V - 415V/50 Hz/Air Charge Air Cooling



Optional equipment and finishing shown. Standard may vary.

PRODUCT HIGHLIGHTS

// Benefits

- Low fuel consumption
- Optimized system integration ability
- High reliability and availability of power
- Long maintenance intervals
- Optimized ratio between size and power
- Wide operating range without derating

// MTU Onsite Energy is a single-source supplier

// Global product support

// Standards

- Engine-generator set is designed and manufactured in facilities certified to standards ISO 2008:9001 and ISO 2004:14001
- Generator set complies to G3 according to ISO 8528
- Generator meets NEMA MG1, BS5000, ISO, DIN EN and IEC standards
- NFPA 110

// Power Rating

- System rating: 750 kVA
- Accepts rated load in one step per NFPA 110
- Generator set complies to G3 according to ISO 8528-5
- Generator set exceeds load steps according to ISO 8528-5

// Performance Assurance Certification (PAC)

- Engine-generator set tested to ISO 8528-5 for transient response
- 75% load factor for prime power applications
- Verified product design, quality and performance integrity
- All engine systems are prototype and factory tested

// Complete range of accessories available

- Control panel
- Circuit breaker/power distribution
- Fuel system
- Fuel connections with shut-off valve mounted to base frame
- Starting/charging system
- Exhaust system
- Mechanical radiator
- Container and Canopy

// Emissions

- Fuel consumption optimized
- TA-Luft, Tier 2 compliant and NEA (ORDE) optimization optionally available

// Certifications

- CE certification option
- German Grid Code Certification (BDEW) option

APPLICATION DATA^①

// Engine

		Fuel consumption optimized	Emission optimized ^②
Manufacturer		MTU	MTU
Model		12V2000G16F	12V2000G16F
Type		4-cycle	4-cycle
Arrangement		12V	12V
Displacement:	l	26.8	26.8
Bore:	mm	135	135
Stroke:	mm	156	156
Compression ratio		17.5	17.5
Rated speed:	rpm	1500	1500
Engine governor		ADEC	ADEC
Speed regulation		± 0.25%	± 0.25%
Max power:	kWm	665	665
Mean effective pressure:	bar	19.9	19.9
Air cleaner		Dry	Dry

// Fuel System

Maximum fuel lift:	m	5	5
Total fuel flow:	l/min	30	30

// Fuel Consumption^③

At 100% of power rating:	l/hr	152.2	158.6
At 75% of power rating:	l/hr	116.6	122.0
At 50% of power rating:	l/hr	82.1	85.3

// Lube oil system

Total oil system capacity:	l	80	80
Max. lube oil temperature (alarm):	°C	103	103
Max. lube oil temperature (shutdown):	°C	105	105
Min. lube oil pressure (alarm):	bar	4.5	4.5
Min. lube oil pressure (shutdown):	bar	4	4

// Combustion Air Requirements

Combustion air volume:	m ³ /s	0.74	0.81
Max. air intake restriction:	mbar	40	40

① All data refers only to the engine and is based on ISO standard conditions (25°C and 100m above sea level).

② Emission optimized data refer to TA-Luft optimized and NEA (ORDE) optimized/Tier 2 compliant engines.

③ Values referenced are in accordance with ISO 3046-1. Conversion calculated with fuel density of 0.83 g/ml.

All fuel consumption values refer to rated engine power.

APPLICATION DATA^①

// Cooling/Radiator System

		Fuel consumption optimized	Emission optimized ^②
Coolant flow rate (HT circuit):	m ³ /h	31.6	31.6
Heat rejection to coolant:	kW	280	280
Heat rejection to charge air:	kW	105	130
Heat radiated to ambient:	kW	35	35
Fan power for mech. radiator (40°C):	kWm	34	34
Fan power for mech. radiator (50°C):	kWm	51.1	51.1
Air flow required for mech. radiator (40°C) cooled unit:	m ³ /min	969	969
Air flow required for mech. radiator (50°C) cooled unit:	m ³ /min	1328	1328
Engine coolant capacity (without cooling equipment):	l	63	63
Radiator coolant capacity (40°C):	l	59	59
Radiator coolant capacity (50°C):	l	140	140
Max. coolant temperature (warning):	°C	102	102
Max. coolant temperature (shutdown):	°C	105	105

// Exhaust System

Exhaust gas temp. (after turbocharger):	°C	550	535
Exhaust gas volume:	m ³ /s	2.05	2.2
Maximum allowable back pressure:	mbar	50	50
Minimum allowable back pressure:	mbar	30	30

// Generator

Protection class	IP23	IP23
Insulation class	H	H
Voltage regulation (steady state)	± 0.25%	± 0.25%
Rado interference class	N	N

① All data refers only to the engine and is based on ISO standard conditions (25°C and 100m above sea level).

② Emission optimized data refer to TA-Luft optimized and NEA (ORDE) optimized/Tier 2 compliant engines.

STANDARD AND OPTIONAL FEATURES

// System Ratings (kW/kVA)

Generator model	Voltage	with mechanical radiator		
		kWeI	kVA*	AMPS
Basic: Marathon 575RSL7180	380 V	600	750	1140
Advanced: Marathon 575RSL7181	400 V	600	750	1083
(Low voltage Marathon standard)	415 V	600	750	1043
Basic: Marathon 740RSL7182	380 V	600	750	1140
Advanced: Marathon 740RSL7183	400 V	600	750	1083
(Low voltage Marathon oversized)	415 V	600	750	1043
Leroy Somer LSA 49.1 L11	380 V	600	750	1140
(Low voltage Leroy Somer)	400 V	600	750	1083
	415 V	600	750	1043
Leroy Somer LSA 50.2 M6	380 V	600	750	1140
(Low voltage Leroy Somer oversized)	400 V	600	750	1083
	415 V	600	750	1043

* cos phi = 0,8

// Engine

- 4-Cycle
- Standard single stage air filter
- Oil drain extension & shut-off valve
- Full flow oil filters
- Closed crankcase ventilation
- ADEC electronic isochronous engine governor
- Common rail fuel injection
- Dry exhaust manifold
- Electric starting motor (24V)
- Fuel consumption optimized engine
- TA-Luft optimized engine
- Tier 2 optimized engine
- NEA (ORDE) optimized engine

// Generator

- NEMA MG1, BS5000, ISO, DIN EN and IEC standards
- Self-ventilated
- Superior voltage waveform
- Solid state, volts-per-Hertz regulator
- Ingress protection IP 23
- 3 phase voltage sensing
- 3% maximum harmonic content
- 2/3 pitch stator windings
- No load to full load regulation
- ±0.25% voltage regulation no load to full load
- Brushless alternator with brushless pilot exciter
- 4 pole, rotating field
- Sustained short circuit current of up to 300% of the rated Prime Power/Continuous Power current for up to 10 seconds (Marathon Generators)
- Sustained short circuit current of up to 300% of the rated current for up to 10 seconds (Leroy Somer Generators)
- Marathon low voltage generator
- Leroy Somer generator
- Oversized generator

Represents standard features

Represents optional features

STANDARD AND OPTIONAL FEATURES, CONTINUATION

// Cooling System

- Jacket water pump
- Thermostat(s)
- Air charge air cooling
- Mechanical radiator
- Jacket water heater

// Control Panel

- Pre-wired control cabinet for easy application of customized controller (V1+)
- Island operation (V2)
- Automatic mains failure operation with ATS (V3a)
- Automatic mains failure operation incl. control of generator and mains breaker (V3b)
- Island parallel operation of multiple gensets (V4)
- Automatic mains failure operation with short (< 10s) mains parallel overlap synchronization (V5)
- Mains parallel operation of a single genset (V6)
- Mains parallel operation of multiple gensets (V7)
- Basler controller
- Deif controller
- Complete system metering
- Digital metering
- Engine parameters
- Generator protection functions
- Engine protection
- SAE J1939 engine ECU communications
- Parametrization software
- Multilingual capability
- Multiple programmable contact inputs
- Multiple contact outputs
- Event recording
- IP 54 front panel rating with integrated gasket
- Different expansion modules
- Remote annunciator
- Daytank control
- Generator winding temperature monitoring
- Generator bearing temperature monitoring
- Differential protection with multi-function protection relay
- Modbus RTU-TCP gateway

// Circuit Breaker/Power Distribution

- 3-pole circuit breaker
- 4-pole circuit breaker
- Manual-actuated circuit breaker
- Electrical-actuated circuit breaker
- Base frame mounted circuit breaker
- Stand-alone circuit breaker in separate switch box

// Fuel System

- Flexible fuel connectors mounted to base frame
- Fuel filter with water separator
- Switchable fuel filter with water separator
- Fuel cooler

STANDARD AND OPTIONAL FEATURES, CONTINUATION

// Starting/Charging System

- 24V starter
- Starter batteries
- Battery charger
- Redundant starter

// Mounting System

- Welded base frame
- Resilient engine and generator mounting
- Modular base frame design

// Enclosures and Containers

- Canopy
- 20 foot container

// Exhaust System

- Exhaust bellows with connection flange
- Exhaust silencer with 10 dB(A) sound attenuation
- Exhaust silencer with 30 dB(A) sound attenuation
- Exhaust silencer with 40 dB(A) sound attenuation
- Y-connection-pipe

WEIGHTS AND DIMENSIONS

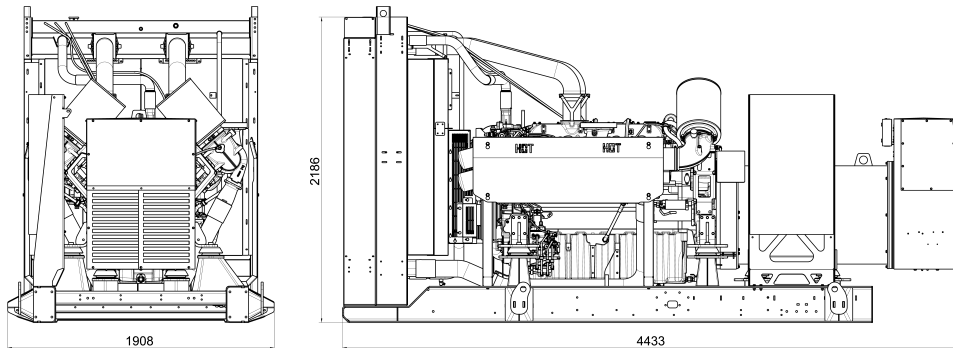

Drawing above for illustration purposes only, based on a standard open power 400 Volt engine-generator set. Lengths may vary with other voltages. Do not use for installation design. See website for unit specific template drawings.

System

Open Power Unit (OPU)

Dimensions (L x W x H)

4440 x 1910 x 2190 mm

Weight (dry/less tank)

6260 kg

Weights and dimensions are based on open power units and are estimates only. Consult the factory for accurate weights and dimensions for your specific engine-generator set.

SOUND DATA

// Consult your local MTU Onsite Energy distributor for sound data.

EMISSIONS DATA

// Consult your local MTU Onsite Energy distributor for emissions data.

RATING DEFINITIONS AND CONDITIONS

// Prime power ratings apply to installations where utility power is unavailable or unreliable. At varying load, the number of generator set operating hours is unlimited. A 10% overload capacity is available for one hour in twelve. Ratings are in accordance with ISO 8528-1, ISO 3046-1, BS 5514 and AS 2789. Average load factor: $\leq 75\%$. Operating hours/year: unlimited

// Deration factor:

Altitude: Consult your local MTU Onsite Energy Power Generation distributor for altitude derations.

Temperature: Consult your local MTU Onsite Energy Power Generation distributor for temperature derations.

Rated power is available up to 40°C and 400m above sea level.

Materials and specifications subject to change without notice.

MTU Onsite Energy

A Rolls-Royce Power Systems Brand

www.mtuonsiteenergy.com